

CS2065

(A462)

CS2065 (A462)

Location of Unit	3
1. Exteriro (A462)	4
2. Transport 1 (A462)	6
3. Transport 2 (A462)	8
4. Distribution (A462)	10
5. Drive Section (A462)	12
6. Upper Solenoid Control Board (A462)	14
7. Lower Solenoid Control Board (A462)	16
8. Receiver Sensor Board (A462)	18
9. Light Sensor Board (A462)	20
10. Sorter Main Board (A462)	22
11. Main Sensor Board (A462)	24
12. Harness Layout (A462)	26
13. Main Harness (A462)	28
14. Power Supply Harness (A462)	30
15. Door Switch Harness (A462)	32
16. Transport Harness (A462)	34
17. Upper Sensor, Middle Sensor and Clutch Harnesses (A462)	36
18. Decal and Document (A462)	38
Parts Index	42

1. EXTERIOR

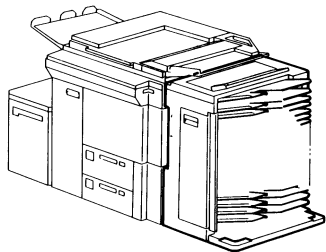

See page 4

2. TRANSPORT 1

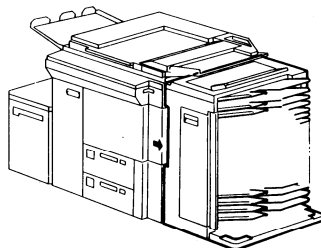

See page 6

3. TRANSPORT 2

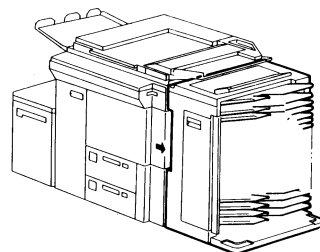

See page 8

4. DISTRIBUTION

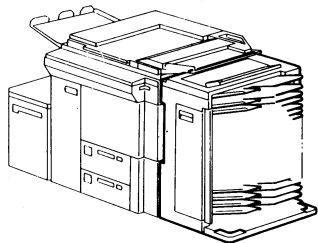

See page 10

5. DRIVE SECTION

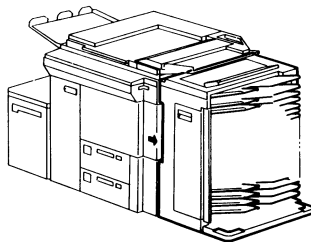

See page 12

1. EXTERIOR (A462)

April 30, '89

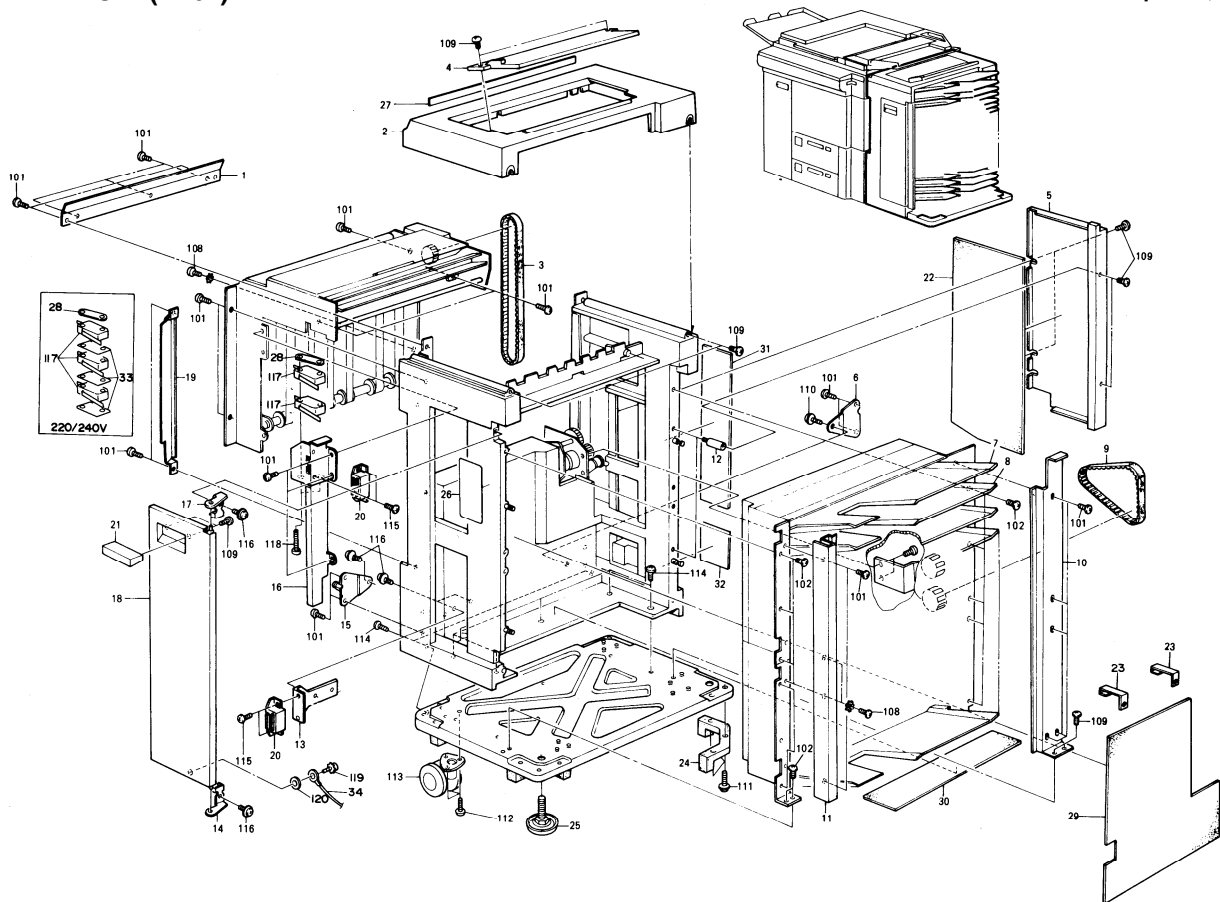

1. EXTERIOR (A462)

April 30, '89

Index No.	Part No.	Description	Q'ty Per Assembly
1	5887 1110	Upper Cover Mounting Plate	1
2	A462 1201	Upper Cover	1
3	5887 2341	Timing Belt - 320XL	1
4	A462 3375	Manual Feed Table - LT	1
4	A462 3365	Manual Feed Table - A4	1
5	A462 1216	Rear Cover	1
6	5937 1164	Rear Connector Bracket	1
7	5887 3281	Proof Tray	1
8	5887 4250	Sorting Bin	1
9	5887 2340	Timing Belt - 166XL	2
10	5887 1114	Distribution Support Bracket	1
11	A462 1226	Indicator Plate - Bin Number	1
12	5887 4381	Stud - Rear Cover	2
13	5937 1254	Magnet Bracket	1
14	5887 1252	Hinge - Lower Frame	1
15	5937 1161	Front Connector Bracket	1
16	5937 1270	Front Safety Cover	1
17	5887 1251	Hinge - Upper Frame	1
18	A462 1205	Front Cover	1
19	A462 1221	Small Front Cover	1
20	5054 0536	Magnet Catch Ass'y	2
21	A458 4147	Hand Grip	1
22	5887 4536	Noise Insulating Pad - Rear	1
23	5887 4537	Vibration Damper Clamp	2
24	5442 1053	Rear Grip - Bottom Plate	4
25	5424 1064	Screw Stand	4
26	A462 4510	Decal - Misfeed Removal 7	1
26	A462 4515	Decal - Misfeed Removal 7 - Multi	1
27	5887 1202	Magnet - Upper Cover	1
28	5056 0509	Nut Plate - Microswitch	1
29	5937 4530	Inside Vibration Damper	1
30	5937 4531	Bottom Vibration Damper	1
31	5937 4532	Upper Vibration Damper	1
32	5937 4533	Lower Vibration Damper	1
33	5887 4520	Insulating Sheet - 220V	3

Index No.	Part No.	Description	Q'ty Per Assembly
34	5887 5782	Grounding Wire - Front Cover	1
101	0314 0060W	Philips Pan Head Screw - M4x6	
102	0314 0080W	Philips Pan Head Screw - M4x8	
103	0720 0040E	Retaining Ring - M4	
104	0720 0050E	Retaining Ring - M5	
105	0720 0060E	Retaining Ring - M6	
107	0575 0060E	Hexagon Headless Set Screw - M5x6	
108	0801 1185	Philips Truss Head Screw - M4x8	
109	0344 0080D	Philips Truss Head Screw - M4x8	
110	0965 4010W	Tapping Screw With Flat Washer - M4x10	
111	0951 4016W	Philips Screw With Flat Washer - M4x16	
112	0315 0080W	Philips Pan Head Screw - M5x8	
113	0805 5003	Caster	
114	0315 0120W	Philips Pan Head Screw - M5x12	
115	0313 0060W	Philips Pan Head Screw - M3x6	
116	0965 4010W	Tapping Screw With Flat Washer - M4x10	
117	1204 1151	Microswitch - 115V	
117	1204 0795	Microswitch - 220/240V	
118	0313 0250W	Philips Pan Head Screw - M3x25 (115V)	
118	0313 0350W	Philips Pan Head Screw - M3x35 (220V)	
119	0801 1185	Philips Truss Head Screw - M4x8	
120	0704 0040M	Toothed Washer - M4	

2. TRANSPORT 1 (A462)

April 30, '89

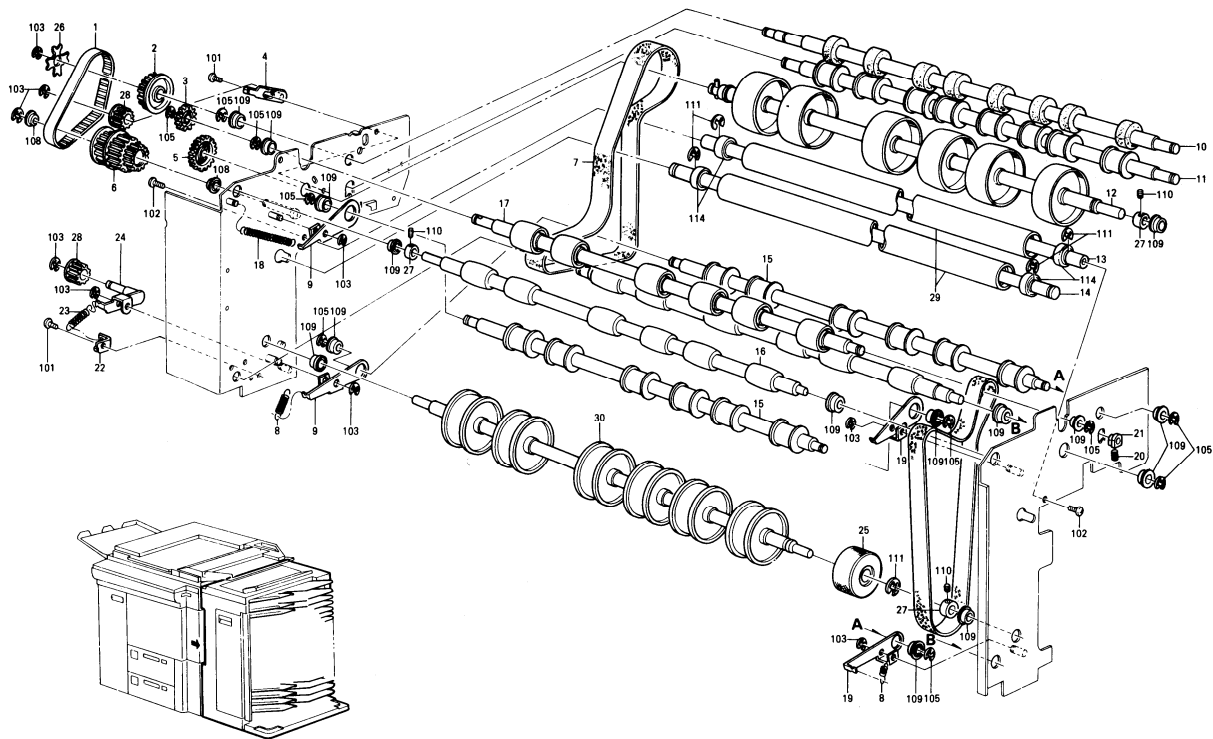

2. TRANSPORT 1 (A462)

April 30, '89

Index No.	Part No.	Description	Q'ty Per Assembly
1	5887 3253	Timing Belt - 134XL	1
2	5887 3252	Pulley - 21T	1
3	5887 3162	Gear - 30T	1
4	5887 3261	Exit Tension Idler	1
5	5887 3161	Gear - 50T	1
6	5887 3165	Gear & Pulley - 18T, 20T/17T	1
7	5887 9001	Transport Belt - 6pcs/set	1
8	5887 3153	Spring - Transport Belt Tension	3
9	5887 3151	Left Arm - Belt Tension	2
10	5887 3251	Drive Exit Roller	1
11	5887 3256	Lower Exit Roller	1
12	5937 3120	Lower Roller Ass'y - Belt Drive	1
13	5887 3142	Shaft - Upper Belt Roller	1
14	5887 3143	Shaft - Lower Belt Roller	1
15	5937 3136	Belt Tension Roller	2
16	5937 3138	Belt Guide Rller	2
17	5887 3126	Upper Roller - Belt Drive	1
18	5887 2295	Spring - Distribution Driving	1
19	5887 3152	Right Arm - Belt Tension	2
20	5887 3257	Spring - Lower Exit Roller	2
21	5887 4155	Shaft Guide - Turn Driven	2
22	5887 2245	Spring Anchor	1
23	5937 3154	Spring - Transport Drive	1
24	5887 3171	Transport Idler Tension	1
25	A462 3178	Transport Belt Knob	1
26	5442 4495	Slip Clutch	1
27	5053 0449	Collar - Shaft Fixing	4
28	5887 4183	Idler Pulley	2
29	5887 3141	Transport Belt Roller	2
30	5937 3131	Lower Roller - Belt Drive	1

Index No.	Part No.	Description	Q'ty Per Assembly
101	0314 0060W	Philips Pan Head Screw - M4x6	
102	0314 0080W	Philips Pan Head Screw - M4x8	
103	0720 0040E	Retaining Ring - M4	
104	0720 0050E	Retaining Ring - M5	
105	0720 0060E	Retaining Ring - M6	
107	0575 0060E	Hexagon Headless Set Screw - M5x6	
108	0805 3145	Ball Bearing - 6x12x4mm	
109	0805 3291	Ball Bearing - 8x16x5mm	
110	0575 0050E	Hexagon Headless Set Screw - M5x5	
111	0720 0080E	Retaining Ring - M8	
113	0623 0180E	Spring Pin - 3x18mm	
114	0805 3162	Ball Bearing - 10x19x7mm	

3. TRANSPORT 2 (A462)

April 30, '89

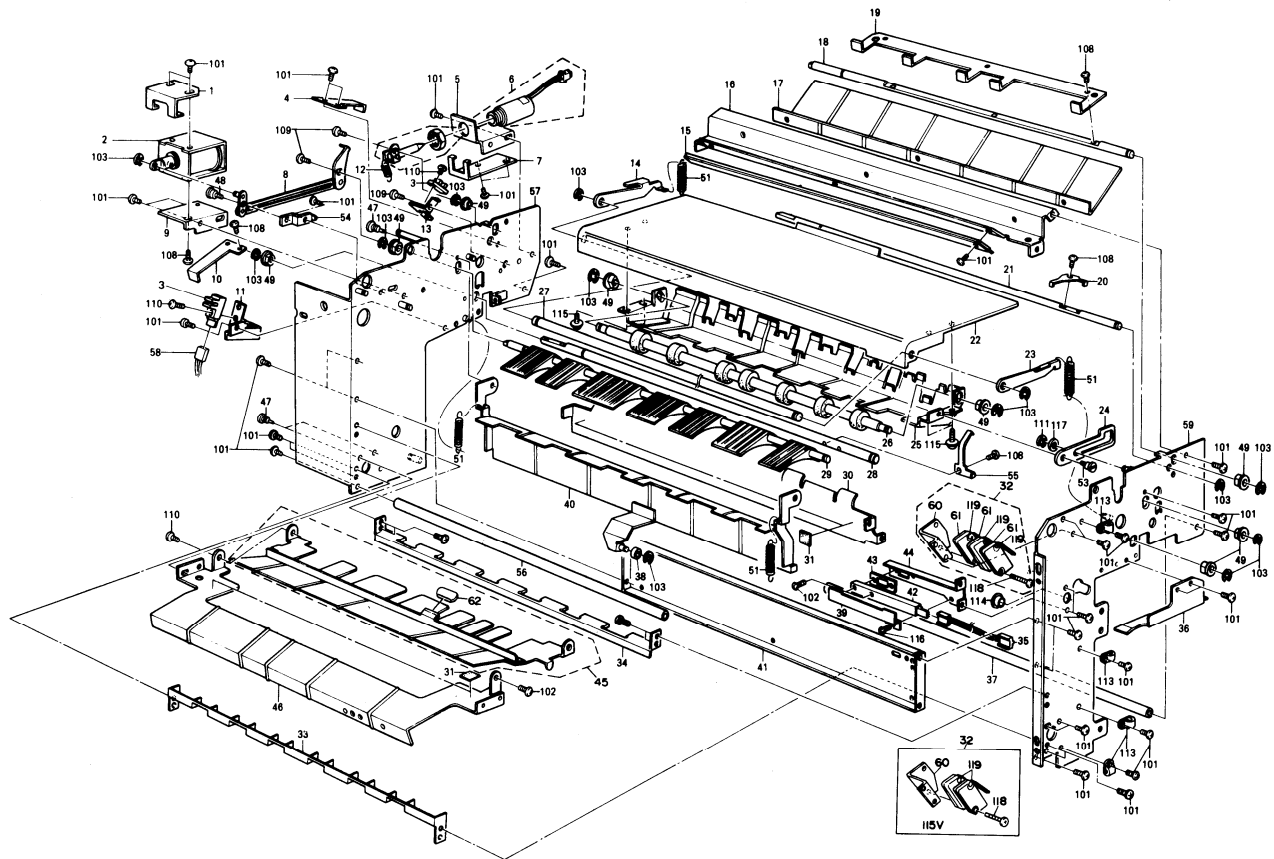

4. DISTRIBUTION (A462)

April 30, '89

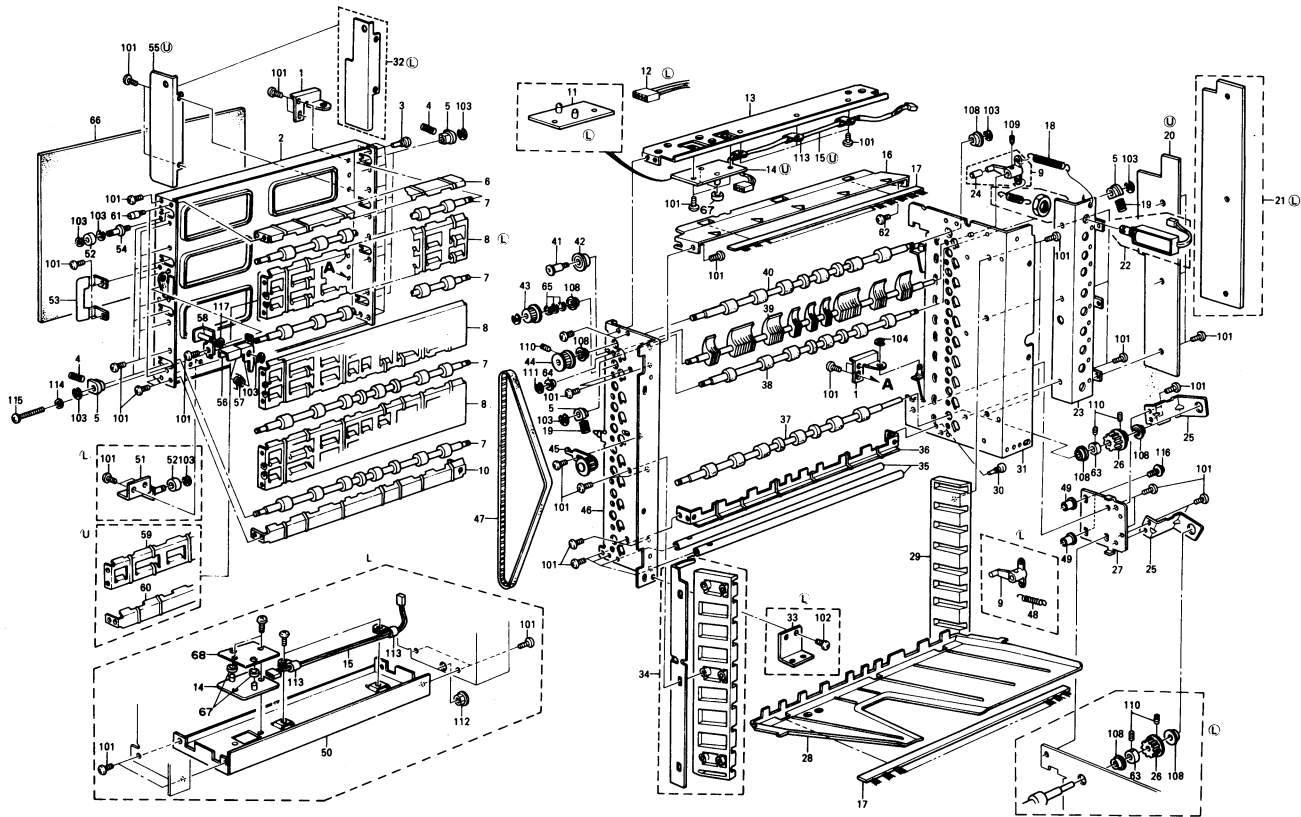

5. DRIVE SECTION (A462)

April 30, '89

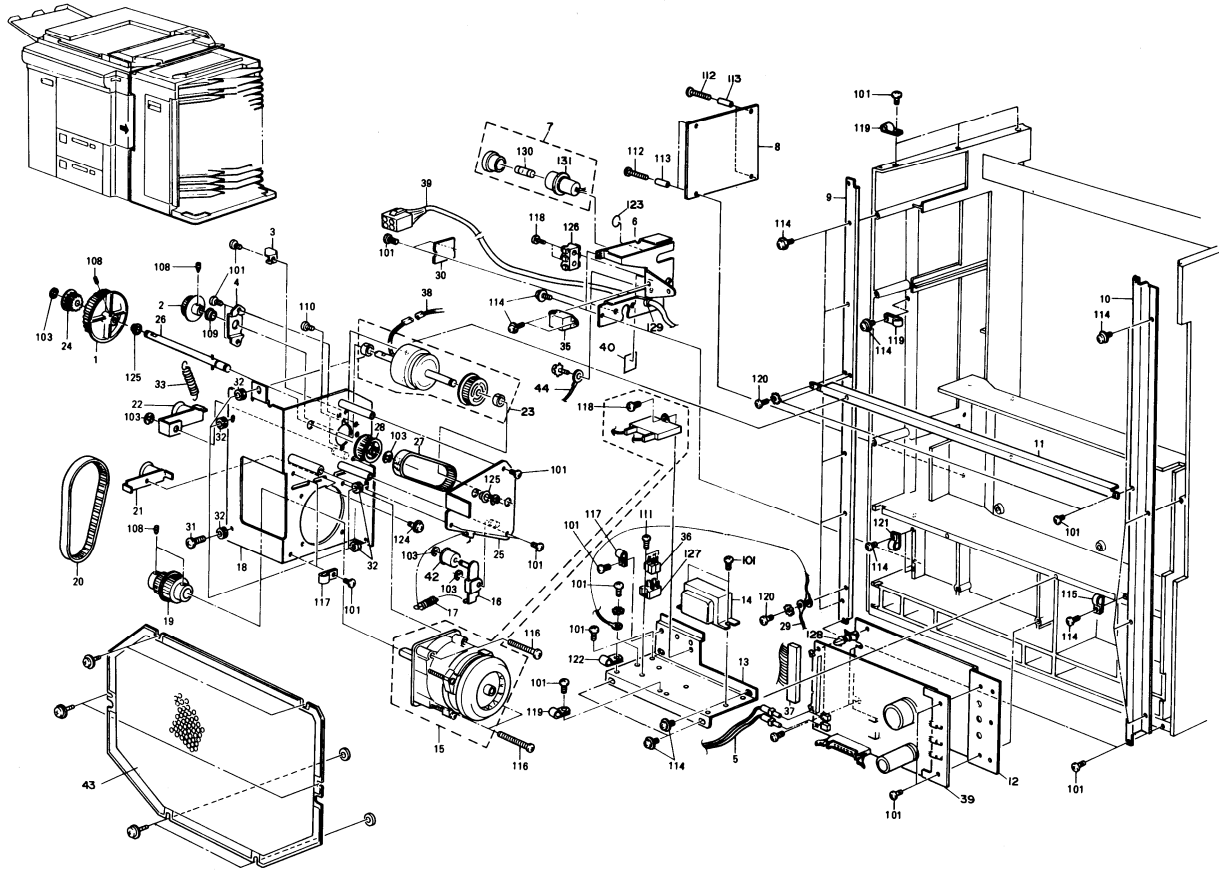

6. UPPER SOLENOID CONTROL BOARD (A462)

April 30, '89

CONNECTOR

SYMBOL NO.	INDEX NO.
CN11	101
CN12	101
CN13	101
CN14	101
CN15	101
CN16	101
CN17	101
CN18	101
CN19	101
CN291	103

IC

SYMBOL NO.	INDEX NO.	SYMBOL NO.	INDEX NO.
CN292	102	IC291	105
CN293	102	IC292	105
CN294	104		

6. UPPER SOLENOID CONTROL BOARD (A462)

April 30, '89

Index No.	Part No.	Description	Q'ty Per Assembly
*	5887 5652	Upper Solenoid Control Board	1

Index No.	Part No.	Description	Q'ty Per Assembly
101	1102 1055	Connector - 2P	
102	1102 1056	Connector - 4P	
103	1103 0510	Connector - 10P	
104	1103 0512	Connector - 12P	
105	1401 0192	IC - μ PA2003C	

7. LOWER SOLENOID CONTROL BOARD (A462)

April 30, '89

CONNECTOR

SYMBOL NO.	INDEX NO.
CN1	101
CN2	101
CN3	101
CN4	101
CN5	101
CN6	101
CN7	101
CN8	101
CN9	101
CN10	101

IC

SYMBOL NO.	INDEX NO.
CN281	103
CN282	102
CN283	103
CN284	104

SYMBOL NO.	INDEX NO.
IC281	105
IC281	105

7. LOWER SOLENOID CONTROL BOARD (A462)

April 30, '89

Index No.	Part No.	Description	Q'ty Per Assembly
*	5887 5662	Lower Solenoid Control Board	1

Index No.	Part No.	Description	Q'ty Per Assembly
101	1102 1055	Connector - 2P	
102	1102 1056	Connector - 4P	
103	1103 0505	Connector - 3P	
104	1103 0512	Connector - 12P	
105	1401 0192	IC - μ PA2003C	

8. RECEIVER SENSOR BOARD (A462)

April 30, '89

TRANSISTOR

SYMBOL NO.	INDEX NO.
Q251	102
Q252	102
Q253	103
Q254	103

PHOTE TRANSISTOR

SYMBOL NO.	INDEX NO.
PH1	104
PH2	104

DIODE

SYMBOL NO.	INDEX NO.
ZD251	105

CONNECTOR

SYMBOL NO.	INDEX NO.
CN250	101

CAPACITOR

SYMBOL NO.	INDEX NO.
C251	106
C252	106
C253	107
C254	108
C255	107
C256	108

RESISTOR

SYMBOL NO.	INDEX NO.	SYMBOL NO.	INDEX NO.
R251	112	R261	111
R252	109	R262	113
R253	112	R263	111
R254	115	R264	114
R255	109	R265	114
R256	110		
R257	113		
R258	110		
R259	115		
R260	113		

8. RECEIVER SENSOR BOARD (A462)

April 30, '89

Index No.	Part No.	Description	Q'ty Per Assembly
*	5937 5632	Receiver Sensor Board	1

Index No.	Part No.	Description	Q'ty Per Assembly
101	1102 1792	Connector - 4P	
102	1400 0045	Transistor - 2SC372	
103	1400 0236	Transistor - 2SK30A-GR	
104	1400 0323	Transistor - PN108	
105	1402 0481	Zener Diode - HZ18-2	
106	1604 1320	Capacitor - 10 μ F 50V	
107	1604 1321	Capacitor - 0.47 μ F 50V	
108	1606 0531	Capacitor - 0.01 μ F 50V	
109	1611 4102	Resistor - 1KOHM 1/4T \pm 5%	
110	1611 4103	Resistor - 10KOHM 1/4T \pm 5%	
111	1611 4105	Resistor - 1KOHM 1/4T \pm 5%	
112	1611 4225	Resistor - 2.2KOHM 1/4T \pm 5%	
113	1611 4471	Resistor - 470OHM 1/4T \pm 5%	
114	1611 4472	Resistor - 4.7KOHM 1/4T \pm 5%	
115	1611 4473	Resistor - 47KOHM 1/4T \pm 5%	

9. LIGHT SENSOR BOARD (A462)

April 30, '89

CAPACITOR

SYMBOL NO.	INDEX NO.
C270	108
C271	107
C272	108

CONNECTOR

SYMBOL NO.	INDEX NO.
CN270	101

IC

SYMBOL NO.	INDEX NO.
IC270	105

LED

SYMBOL NO.	INDEX NO.
LED270	104
LED271	104
LED272	104
LED273	104

TRANSISTOR

SYMBOL NO.	INDEX NO.
Q270	103
Q271	102

RESISTOR

SYMBOL NO.	INDEX NO.
R270	106
R271	110
R272	112
R273	114
R274	111
R275	113
R276	109

9. LIGHT SENSOR BOARD (A462)

April 30, '89

Index No.	Part No.	Description	Q'ty Per Assembly
*	5887 5633	Light Sensor Board	1

Index No.	Part No.	Description	Q'ty Per Assembly
101	1102 1791	Connector - 3P	
102	1400 0113	Transistor - 2SA495GTMY	
103	1400 0284	Transistor - 2SD789D	
104	1403 0247	LED - LN51L	
105	1408 0124	IC - LM555CN	
106	1600 0549	Resistor - 820HM 2T $\pm 10\%$	
107	1606 0531	Capacitor - 0.01 μ F 50V	
108	1606 0533	Capacitor - 0.01 μ F 50V	
109	1611 4154	Resistor - 150KOHM 1/4T $\pm 5\%$	
110	1611 4182	Resistor - 1.8KOHM 1/4T	
111	1611 4223	Resistor - 22KOHM 1/4T $\pm 5\%$	
112	1611 4473	Resistor - 47KOHM 1/4T $\pm 5\%$	
113	1611 4563	Resistor - 56KOHM 1/4T $\pm 5\%$	
114	1611 4152	Resistor - 1.5KOHM 1/4T $\pm 5\%$	

10. SORTER MAIN BOARD (A462)

April 30, '89

CAPACITOR

SYMBOL NO.	INDEX NO.
C101	139
C102	139
C103	139
C104	139
C105	136
C106	139
C107	139
C108	139
C109	139
C110	139

SYMBOL NO.	INDEX NO.
C111	139
C112	139
C113	139
C114	139
C115	139
C116	139
C117	139
C118	139
C119	139
C120	139

SYMBOL NO.	INDEX NO.
C121	139
C122	139
C123	136
C124	141
C125	141
C126	135
C127	139
C128	139
C129	140
C130	139

SYMBOL NO.	INDEX NO.
C131	138
C132	140
C133	140
C134	137
C135	140
C136	138
C137	139

CONNECTOR

SYMBOL NO.	INDEX NO.
CN101	102
CN102	103
CN112	105
CN113	101
CN115	104
CN116	1
CN117	2

DIODE

SYMBOL NO.	INDEX NO.
D101	114
D102	114
D103	114

DIP SW

SYMBOL NO.	INDEX NO.
DPS101	109

FUSE HOLDER

SYMBOL NO.	INDEX NO.
FH	106

FUSE

SYMBOL NO.	INDEX NO.
FU101	107
FU102	108

RC ARRAY

SYMBOL NO.	INDEX NO.
RB101	134
RB102	134
RB103	134

IC

SYMBOL NO.	INDEX NO.
IC101	112
IC102	112
IC103	112
IC104	121
IC105	117
IC106	122
IC107	122
IC108	122
IC109	112
IC110	121

LED

SYMBOL NO.	INDEX NO.
IC111	117
IC112	3
IC113	120
IC114	121
IC115	118
IC116	119
IC117	4
IC118	123
IC119	112

SYMBOL NO.	INDEX NO.
LED101	116
LED102	116
LED103	116
LED104	116
LED105	116
LED106	116
LED107	116
LED108	116
LED109	116
LED110	116

SYMBOL NO.	INDEX NO.
LED111	116
LED112	116
LED113	116
LED114	116

OSCILLATOR

SYMBOL NO.	INDEX NO.
OSC101	125

PHOTE TRANSISTOR

SYMBOL NO.	INDEX NO.
PT101	124

TRANSISTOR

SYMBOL NO.	INDEX NO.
Q101	113

RESISTOR

SYMBOL NO.	INDEX NO.
R103	126
R104	143
R105	146
R106	146
R107	142
R108	146
R109	142
R110	142
R111	142
R112	142

SYMBOL NO.	INDEX NO.
R113	142
R114	143
R115	145
R116	144
R117	146
R118	147
R119	146
R120	146

RESISTOR ARRAY

SYMBOL NO.	INDEX NO.
RAY101	132
RAY102	133
RAY103	133
RAY104	133
RAY105	133
RAY106	129
RAY107	130
RAY108	133
RAY109	133
RAY110	133

SYMBOL NO.	INDEX NO.
RAY111	131
RAY112	128
RAY113	133
RAY114	133
RAY115	133
RAY116	127

SSR

SYMBOL NO.	INDEX NO.
SSR101	111

RECTIFIER

SYMBOL NO.	INDEX NO.
ST101	115
ST102	115

SM

SYMBOL NO.	INDEX NO.
SM101	110
SM102	110
SM103	110
SM104	110

10. SORTER MAIN BOARD (A462)

April 30, '89

Index No.	Part No.	Description	Q'ty Per Assembly
1	5918 5711	Fiber Output Connector	1
2	5918 5712	Fiber Input Connector	1
3	5937 5613	IC - HN4827128G-25	1
4	5937 5604	IC - SI-3242P	1
*	5937 5612	Sorter Main Board	1
101	1102 0911	Connector - 8P	
102	1102 0995	Connector - 2P	
103	1102 1039	Connector - 4P	
104	1102 2566	Connector - 2P	
105	1103 0755	Connector - 50P	
106	1104 0307	Fuse Clip	
107	1107 0411	Fuse - 2A	
108	1107 0413	Fuse - 3A	
109	1204 0758	DIP Switch	
110	1204 1385	Push Switch	
111	1208 1024	Solid State Relay - 220/240V	
112	1401 0192	IC - μ PA2003C	
113	1401 0234	Transistor - 2SD686	
114	1401 0832	Diode - DSA1A1	
115	1402 0291	Rectifier - S2VB10	
116	1403 0308	LED - TLR-102A	
117	1407 0711	IC - 74LSI51N	
118	1407 0887	IC - SN74LS244N	
119	1407 1026	IC - SN74LS373N	
120	1407 1334	IC - UPD7810G	
121	1407 1607	IC - TD62603P	

Index No.	Part No.	Description	Q'ty Per Assembly
122	1407 1698	IC - TD62801P	
123	1408 0383	IC - SI-3052V	
124	1408 0408	IC - PST518A	
125	1503 0070	Ceramic Oscillator - 10MHz	
126	1600 0544	Resistor - 1KOHM 1T \pm 1%	
127	1601 7284	Resistor Array - 4.7KOHM 1/8W \pm 5%	
128	1601 7348	Resistor Array - 470OHM 1/8W \pm 5%	
129	1601 7349	Resistor Array - 1.5KOHM 1/8T \pm 5%	
130	1601 7352	Resistor Array - 4.7KOHM	
131	1601 7370	Resistor Array - 1KOHM	
132	1601 7371	Resistor Array - 1.5KOHM	
133	1601 7374	Resistor Array - 4.7KOHM	
134	1602 0911	RC Array - RC082	
135	1604 0938	Capacitor - 4700 μ F 35V	
136	1604 0987	Capacitor - 10MF 16V	
137	1604 1130	Capacitor - 2200 μ F 50V	
138	1604 1254	Capacitor - 47 μ F 50V	
139	1606 0533	Capacitor - 0.01 μ F 50V	
140	1606 0658	Capacitor - 0.1 μ F 50V	
141	1606 1430	Capacitor - 27PF 50V	
142	1611 4102	Resistor - 1KOHM 1/4T \pm 5%	
143	1611 4103	Resistor - 10KOHM 1/4T \pm 5%	
144	1611 4106	Resistor - 10MOHM 1/4T \pm 5%	
145	1611 4152	Resistor - 1.5KOHM 1/4T \pm 5%	
146	1611 4472	Resistor - 4.7KOHM 1/4T \pm 5%	
147	1611 4473	Resistor - 47KOHM 1/4T \pm 5%	

11. MAIN SENSOR BOARD (A462)

April 30, '89

CAPACITOR

SYMBOL NO.	INDEX NO.
C201	109
C202	108
C203	108
C204	108
C205	108
C206	109
C207	107
C208	107
C209	107
C210	109

CONNECTOR

SYMBOL NO.	INDEX NO.
C211	107

SYMBOL NO.	INDEX NO.
CN201	101

DIODE

SYMBOL NO.	INDEX NO.
D201	103
D202	103
D203	103
D204	103

DIP SW

SYMBOL NO.	INDEX NO.
DPS201	102

IC

SYMBOL NO.	INDEX NO.
IC201	105
IC202	105
IC203	105

LED

SYMBOL NO.	INDEX NO.
LED201	104
LED202	104
LED203	104
LED204	104
LED205	104
LED206	104
LED207	104

RESISTOR

SYMBOL NO.	INDEX NO.
R201	110
R202	110
R203	110
R204	110
R205	113
R206	113
R207	113
R208	113
R209	113
R210	114

SYMBOL NO.	INDEX NO.
R211	114
R212	114
R213	114
R214	113
R215	113
R216	113
R217	111
R218	111
R219	110
R220	110

SYMBOL NO.	INDEX NO.
R221	110
R222	110
R223	113
R224	113
R225	110
R226	113
R227	110
R228	113
R229	110
R230	113

SYMBOL NO.	INDEX NO.
R231	110
R232	113
R233	112
R234	112
R235	112

POTENTIOMETER

SYMBOL NO.	INDEX NO.
UR201	106
UR202	106
UR203	106
UR204	106

11. MAIN SENSOR BOARD (A462)

April 30, '89

Index No.	Part No.	Description	Q'ty Per Assembly
*	5887 5612	Main Sensor Board	1

Index No.	Part No.	Description	Q'ty Per Assembly
101	1103 0515	Connector - 15P	
102	1204 0790	DIP Switch	
103	1401 0611	Diode - 1S1588	
104	1403 0308	LED - TLR-102A	
105	1408 0099	IC - HA17901P	
106	1601 8139	Variable Resistor - 50KOHM 0.5W	
107	1604 1320	Capacitor - 10 μ F 50V	
108	1604 1321	Capacitor - 0.47 μ F 50V	
109	1606 0533	Capacitor - 0.01 μ F 50V	
110	1611 4102	Resistor - 1KOHM 1/4T \pm 5%	
111	1611 4122	Resistor - 1.2KOHM 1/4T \pm 5%	
112	1611 4272	Resistor - 2.7KOHM 1/4T \pm 5%	
113	1611 4472	Resistor - 4.7KOHM 1/4T \pm 5%	
114	1611 4473	Resistor - 47KOHM 1/4T \pm 5%	

12. HARNESS LAYOUT (A462)

April 30, '89

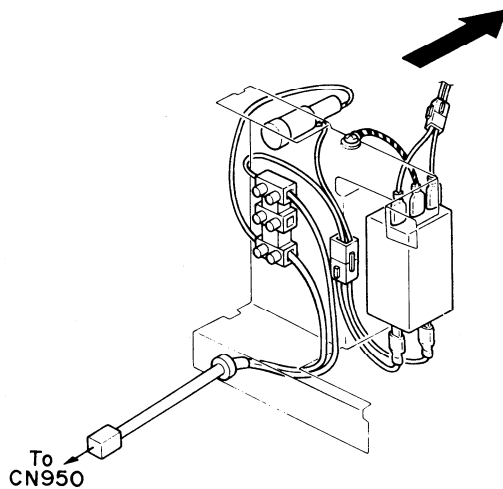
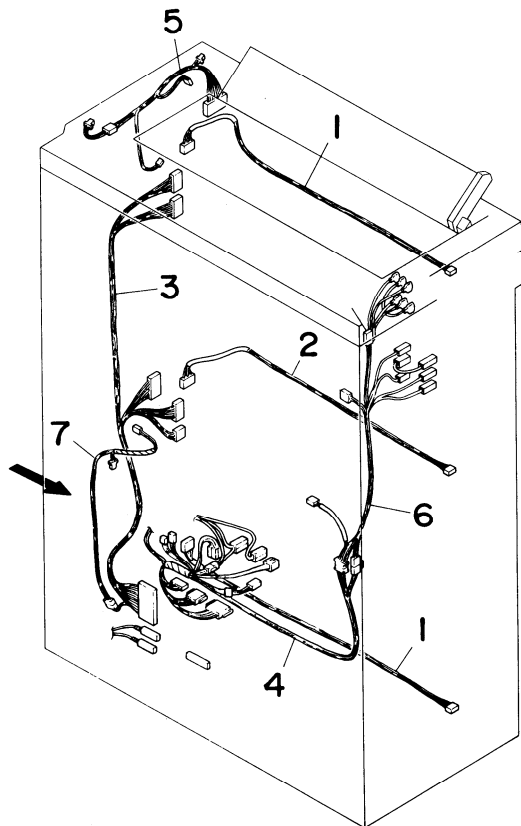

12. HARNESS LAYOUT (A462)

April 30, '89

Index No.	Part No.	Description	Q'ty Per Assembly
1	5887 5625	Upper Sensor Harness	2
2	5887 5635	Middle Sensor Hanes	1
3	5887 5701	Main Harness	1
4	5887 5710	Power Supply Harness	1
5	5887 5720	Transport Harness	1
6	5887 5730	Door Switch Harness	1
7	5887 5740	Clutch Harness	1

Index No.	Part No.	Description	Q'ty Per Assembly
-----------	----------	-------------	-------------------

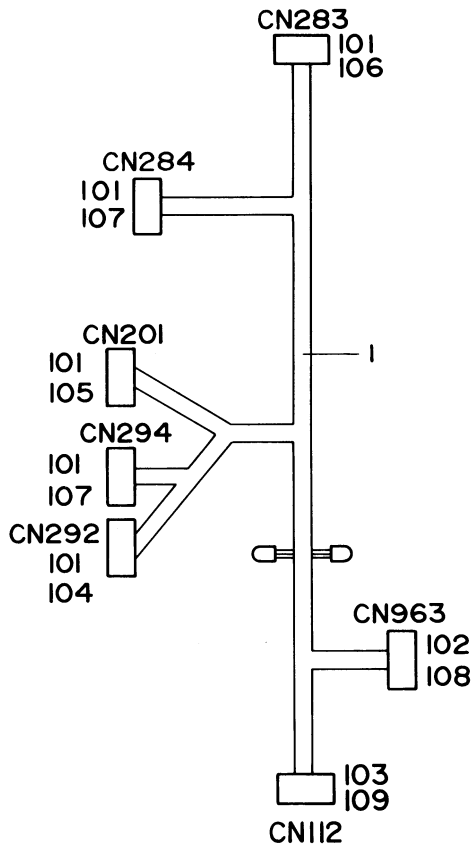

13. MAIN HARNESS (A462)

April 30, '89

Index No.	Part No.	Description	Q'ty Per Assembly
1	5887 5701	Main Harness	1

Index No.	Part No.	Description	Q'ty Per Assembly
101	1100 1147	Socket - Mate-N-Lock	
102	1100 1159	Socket - Mate-N-Lock	
103	1100 1182	Socket - Mate-N-Lock	
104	1102 1213	Connector - 4P	
105	1102 1244	Connector - 15P	
106	1102 1293	Connector - 10P	
107	1102 1295	Connector - 12P	
108	1102 1308	Connector - 6P	
109	1103 0657	Connector - 50P	

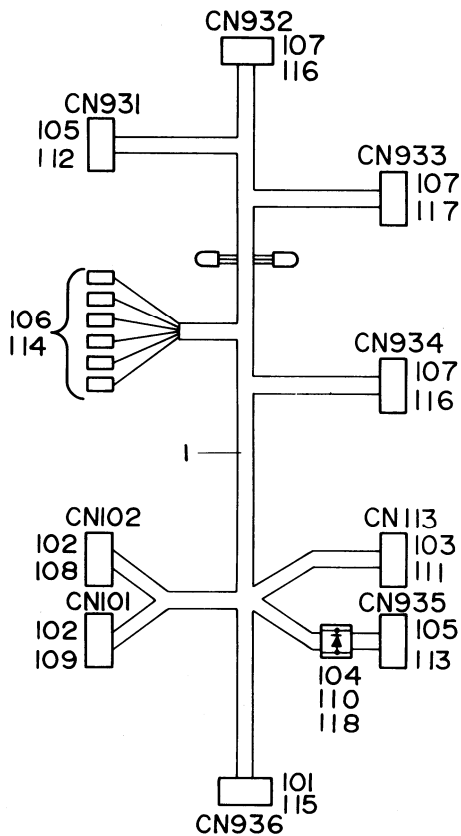

14. POWER SUPPLY HARNESS (A462)

April 30, '89

Index No.	Part No.	Description	Q'ty Per Assembly
1	5887 5710	Power Supply Harness	1

Index No.	Part No.	Description	Q'ty Per Assembly
101	1100 1239	Pin - Mate-N-Lock	
102	1100 1042	Socket - Mate-N-Lock	
103	1100 1147	Socket - Mate-N-Lock	
104	1100 1155	Contact	
105	1100 1159	Socket - Mate-N-Lock	
106	1100 1172	Fastening Receptacle	
107	1100 1241	Socket - Mate-N-Lock	
108	1102 0782	Pin Housing - Mate-N-Lock	
109	1102 0983	Connector - 2P	
110	1102 1286	Connector	
111	1102 1291	Connector - 8P	
112	1102 1309	Connector - 8P	
113	1102 1396	Connector - 2P	
114	1102 1404	Receptacle Housing	
115	1102 1507	Connector - 2P	
116	1102 1515	Connector - 2P	
117	1102 1518	Connector - 6P	
118	1402 0247	Diode - W06B	

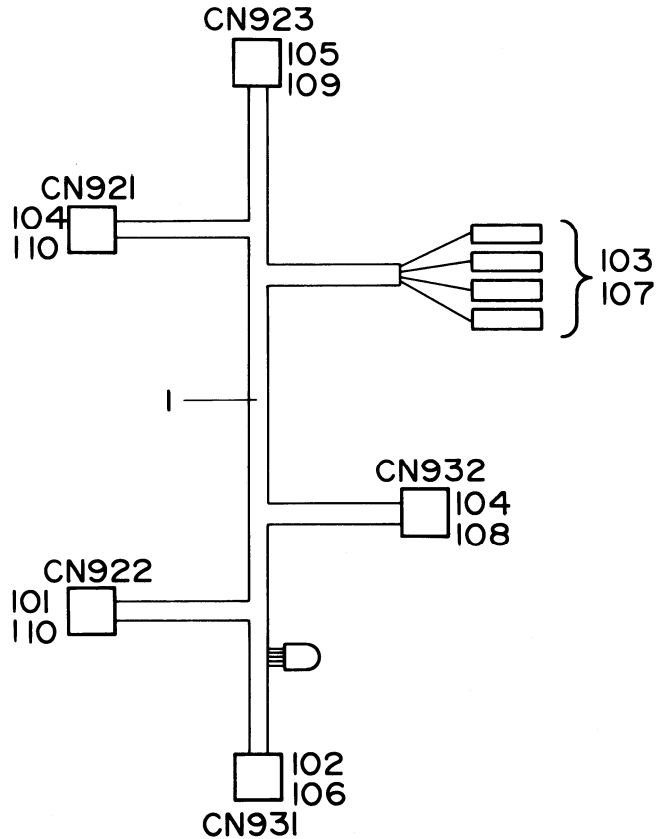

15. DOOR SWITCH HARNESS (A462)

April 30, '89

Index No.	Part No.	Description	Q'ty Per Assembly
1	5887 5730	Door Switch Harness	1

Index No.	Part No.	Description	Q'ty Per Assembly
101	1100 1147	Socket - Mate-N-Lock	
102	1100 1159	Socket - Mate-N-Lock	
103	1100 1169	Fastening Receptacle	
104	1100 1239	Pin - Mate-N-Lock	
105	1100 1241	Socket - Mate-N-Lock	
106	1102 1309	Connector - 8P	
107	1102 1408	Connector - 1P	
108	1102 1507	Connector - 2P	
109	1102 1517	Connector - 4P	
110	1103 0600	Connector - 3P	

16. TRANSPORT HARNESS (A462)

April 30, '89

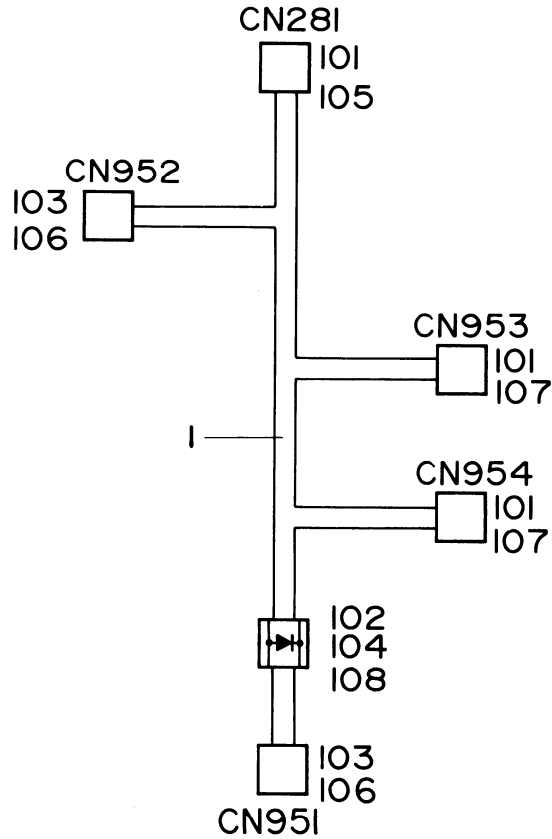

16. TRANSPORT HARNESS (A462)

April 30, '89

Index No.	Part No.	Description	Q'ty Per Assembly
1	5887 5720	Transport Harness	1

Index No.	Part No.	Description	Q'ty Per Assembly
101	1100 1147	Socket - Mate-N-Lock	
102	1100 1155	Contact	
103	1100 1159	Socket - Mate-N-Lock	
104	1102 1286	Connector	
105	1102 1293	Connector - 10P	
106	1102 1396	Connector - 2P	
107	1103 0600	Connector - 3P	
108	1402 0247	Diode - W06B	

17. UPPER SENSOR, MIDDLE SENSOR AND CLUTCH HARNESSSES (A462)

April 30, '89

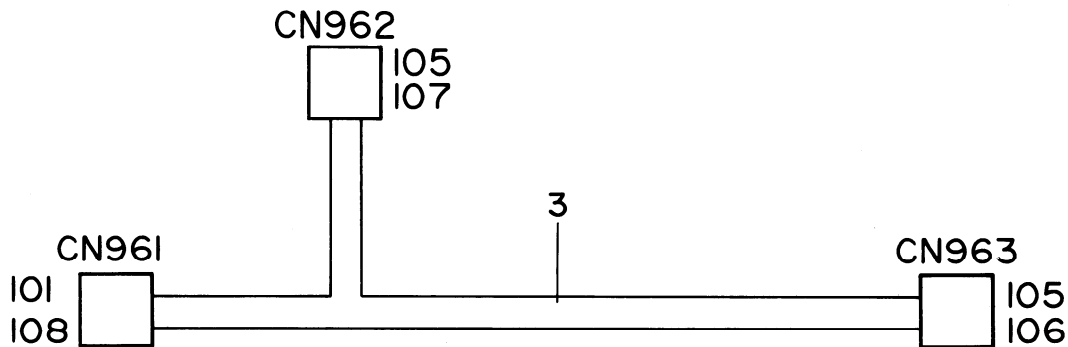
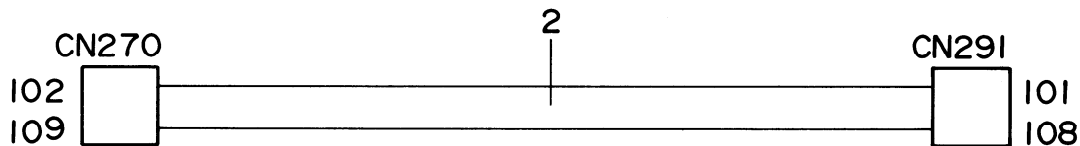
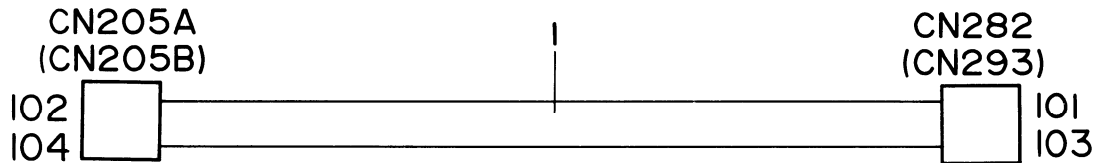

17. UPPER SENSOR, MIDDLE SENSOR AND CLUTCH HARNESES (A462)

April 30, '89

Index No.	Part No.	Description	Q'ty Per Assembly
1	5887 5625	Upper Sensor Harness	2
2	5887 5635	Middle Sensor Harness	1
3	5887 5740	Clutch Harness	1

Index No.	Part No.	Description	Q'ty Per Assembly
101	1100 1147	Socket - Mate-N-Lock	
102	1100 1274	Fastening Receptacle	
103	1102 1213	Connector - 4P	
104	1102 1794	Connector - 4P	
105	1100 1159	Socket - Mate-N-Lock	
106	1102 1308	Connector - 6P	
107	1102 1396	Connector - 2P	
108	1103 0600	Connector - 3P	
109	1102 1793	Connector - 3P	

1

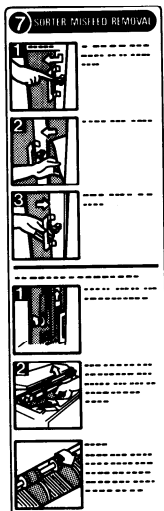

2

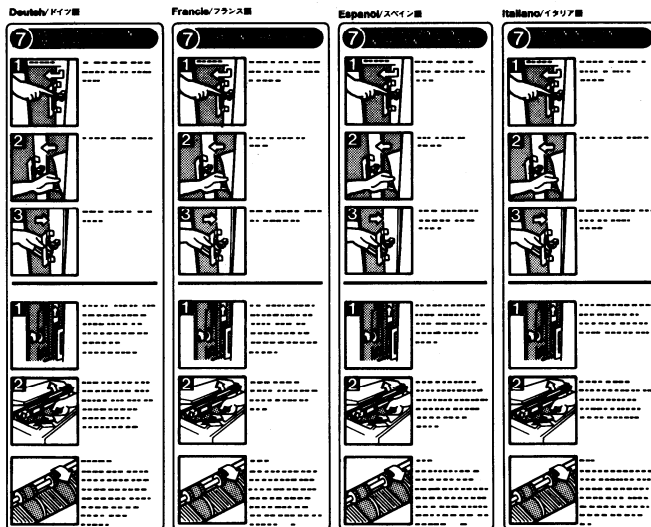

3

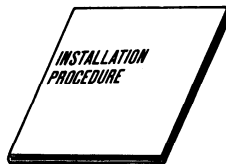

18. DECAL AND DOCUMENT (A462)

April 30, '89

Index No.	Part No.	Description	Q'ty Per Assembly
1	A462 4510	Decal - Misfeed Removal 7	1
2	A462 4515	Decal - Misfeed Removal 7 - Multi	1
3	A462 8610	Installation Procedure - English	1
3	A462 8615	Installation Procedure - Multi	1

Index No.	Part No.	Description	Q'ty Per Assembly
-----------	----------	-------------	-------------------

PARTS INDEX

Parts No.	Description	Page and Index No.
A462 1201	Upper Cover	5-2
A462 1205	Front Cover	5-18
A462 1216	Rear Cover	5-5
A462 1221	Small Front Cover	5-19
A462 1226	Indicator Plate - Bin Number	5-11
A462 3178	Transport Belt Knob	7-25
A462 3230	Receiving Upper Guide	9-45
A462 3291	Manual Feed Cover	9-22
A462 3306	Cap - Manual Feed Link	9-24
A462 3365	Manual Feed Table - A4	5-4
A462 3375	Manual Feed Table - LT	5-4
A462 4351	Driven Guide	11-53
A462 4370	Fixed Lever - Driven Unit	11-56
A462 4510	Decal - Misfeed Removal 7	39-1
A462 4510	Decal - Misfeed Removal 7	5-26
A462 4515	Decal - Misfeed Removal 7 - Multi	39-2
A462 4515	Decal - Misfeed Removal 7 - Multi	5-26
A462 8610	Installation Procedure - English	39-3
A462 8615	Installation Procedure - Multi	39-3

Parts No.	Description	Page and Index No.
AW02 0002	Photo Sensor	9-3
A411 2531	Knob Cap	9-62
A458 4147	Hand Grip	5-21
5053 0447	Bushing - 6x10x6mm	9-49
5053 0449	Collar - Shaft Fixing	7-27
5054 0536	Magnet Catch Ass'y	5-20
5056 0509	Nut Plate - Microswitch	5-28
5328 1312	Motor Bracket Guide	11-49
5403 2075	Stepped Screw	9-53
5403 4335	Decal - Terminal - 115V	13-40
5403 6246	Stepped Screw - Cleaning	13-31
5409 1855	Mounting Pin	11-62
5413 1882	Stepped Screw	9-48
5413 3903	Pin - Transfer Guide Plate	11-61
5418 1709	Bushing - Lens Shaft	11-63
5424 1064	Screw Stand	5-25
5429 3150	Spring - Paper Feed	9-51
5442 1053	Rear Grip - Bottom Plate	5-24
5442 4495	Slip Clutch	7-26
5447 4980	Decal - Terminal - 220/240V	13-40
5840 2416	Bushing - Pinch Roller	11-64
5886 1066	Tension Roller	13-42
5887 1110	Upper Cover Mounting Plate	5-1
5887 1111	Front Support Bracket	13-10
5887 1112	Rear Support Bracket	13-9
5887 1113	Middle Support Bracket	13-11
5887 1114	Distribution Support Bracket	5-10
5887 1115	Front Support Frame	11-33
5887 1202	Magnet - Upper Cover	5-27
5887 1251	Hinge - Upper Frame	5-17
5887 1252	Hinge - Lower Frame	5-14
5887 2120	Pulley - 15T/18T	13-19
5887 2124	Driving Support Plate	13-25
5887 2133	Spring - Clutch Tension	13-17
5887 2136	Pulley - 40T	13-1

Parts No.	Description	Page and Index No.
5887 2138	Pulley - 14T	13-24
5887 2150	Pulley - 17T	13-28
5887 2170	Timing Belt - 82XL	13-27
5887 2245	Spring Anchor	7-22
5887 2250	Pulley - 17T	11-26
5887 2250	Pulley - 17T	13-2
5887 2280	Drive Idler Tension	13-21
5887 2285	Distribution Idler Tension	13-22
5887 2295	Spring - Distribution Driving	13-33
5887 2295	Spring - Distribution Driving	7-18
5887 2335	Supporter - Distribution Shaft	11-25
5887 2340	Timing Belt - 166XL	13-20
5887 2340	Timing Belt - 166XL	5-9
5887 2341	Timing Belt - 320XL	5-3
5887 3126	Upper Roller - Belt Drive	7-17
5887 3141	Transport Belt Roller	7-29
5887 3142	Shaft - Upper Belt Roller	7-13
5887 3143	Shaft - Lower Belt Roller	7-14
5887 3151	Left Arm - Belt Tension	7-9
5887 3152	Right Arm - Belt Tension	7-19
5887 3153	Spring - Transport Belt Tension	7-8
5887 3155	Left Bracket - Upper Belt Drive	9-14
5887 3156	Right Bracket - Upper Drive	9-23
5887 3161	Gear - 50T	7-5
5887 3162	Gear - 30T	7-3
5887 3165	Gear & Pulley - 18T, 20T/17T	7-6
5887 3171	Transport Idler Tension	7-24
5887 3176	Stay - Transport Unit	9-56
5887 3185	Bracket - Upper Safety Switch	9-60
5887 3200	Turn Pawl Solenoid	9-2
5887 3201	Turn Pawl	9-29
5887 3205	Bracket - Turn Pawl Solenoid	9-9
5887 3206	Stopper - Turn Pawl Solenoid	9-1
5887 3211	Turn Pawl Fulcrum	9-54
5887 3213	Joint Plate - Turn Pawl	9-8

Parts No.	Description	Page and Index No.
5887 3221	Lower Entrance Guide	9-46
5887 3236	Lower Guide - Turn Pawl	9-40
5887 3245	Guide Plate - Exit Roller	9-30
5887 3246	Cushion - Guide Plate	9-31
5887 3251	Drive Exit Roller	7-10
5887 3252	Pulley - 21T	7-2
5887 3253	Timing Belt - 134XL	7-1
5887 3256	Lower Exit Roller	7-11
5887 3257	Spring - Lower Exit Roller	7-20
5887 3261	Exit Tension Idler	7-4
5887 3268	Antistatic Brush	9-15
5887 3271	Exit Sensor Bracket	9-11
5887 3272	Exit Sensor Actuator	9-10
5887 3273	Exit Sensor Shaft	9-28
5887 3274	Exit Sensor Feeler	9-55
5887 3281	Proof Tray	5-7
5887 3301	Upper Guide - Turn Gate	9-25
5887 3308	Shaft - Manual Feed Cover	9-27
5887 3311	Manual Feed Roller	9-26
5887 3321	Manual Feed Stopper	9-19
5887 3322	Shaft - Manual Feed Stopper	9-18
5887 3327	Bracket - Manual Feed Solenoid	9-5
5887 3328	Stopper - Manual Feed Solenoid	9-7
5887 3330	Return Spring - Manual Feed	9-12
5887 3336	Feeler - Manual Feed Sensor	9-20
5887 3337	Shaft - Manual Feed Sensor	9-21
5887 3338	Bracket - Manual Feed Sensor	9-13
5887 3339	Actuator - Manual Feed Sensor	9-4
5887 4120	Stay - Side Plate	11-35
5887 4120	Stay - Side Plate	9-37
5887 4130	Vertical Drive Roller - A	11-37
5887 4131	Vertical Drive Roller - B	11-40
5887 4132	Vertical Driven Roller	11-7
5887 4133	Exit Roller	11-38
5887 4140	Bin Gate	11-39

Parts No.	Description	Page and Index No.
5887 4150	Bracket - Turn Solenoid	11-23
5887 4155	Shaft Guide - Turn Driven	11-5
5887 4155	Shaft Guide - Turn Driven	7-21
5887 4156	Spring - Driven Roller	11-4
5887 4157	Spring - Exit Roller	11-19
5887 4162	Screw - Driven Guide Plate	11-3
5887 4162	Screw - Driven Guide Plate	9-47
5887 4166	Return Spring - Turn Pawl	11-18
5887 4167	Holder Spring - Turn Pawl	11-48
5887 4170	Relay Guide Bracket	11-36
5887 4171	Relay Guide Bracket - A	11-10
5887 4172	Relay Guide Bracket - B	11-6
5887 4180	Tension Idler - Turn Pawl	11-45
5887 4183	Idler Pulley	7-28
5887 4185	Idler Roller	11-42
5887 4186	Timing Belt - 276XL	11-47
5887 4190	Pulley - 10T	11-44
5887 4193	Pulley - 10T	11-43
5887 4195	Stopper Screw	11-41
5887 4250	Sorting Bin	11-28
5887 4250	Sorting Bin	5-8
5887 4270	Antistatic Brush - Bin	11-17
5887 4280	Paper Guide - Distribution	11-16
5887 4300	Front Guide - Sorting Bin	11-34
5887 4330	Rear Guide - Sorting Bin	11-29
5887 4350	Spring - Return Lever	11-57
5887 4381	Stud - Rear Cover	5-12
5887 4400	Guide Roller - Driven Unit	11-52
5887 4400	Guide Roller - Driven Unit	9-38
5887 4410	Driven Roller Bracket	11-51
5887 4520	Insulating Sheet - 220V	5-33
5887 4520	Insulating Sheet - 220V	9-61
5887 4534	Noise Insulating Pad - Upper	11-66
5887 4536	Noise Insulating Pad - Rear	5-22
5887 4537	Vibration Damper Clamp	5-23

Parts No.	Description	Page and Index No.
5887 5400	Drive Motor - AC35W/115V	13-15
5887 5420	Drive Motor - AC35W/220/240V	13-15
5887 5530	Noise Filter - 115V	13-35
5887 5531	Noise Filter - 220/240V	13-35
5887 5541	Fuse Holder - 220/240V	13-7
5887 5606	Bracket - Main Control Board	13-12
5887 5612	Main Sensor Board	13-8
5887 5612	Main Sensor Board	25-*
5887 5625	Upper Sensor Harness	11-15
5887 5625	Upper Sensor Harness	27-1
5887 5625	Upper Sensor Harness	37-1
5887 5633	Light Sensor Board	11-11
5887 5633	Light Sensor Board	21-*
5887 5635	Middle Sensor Harness	11-12
5887 5635	Middle Sensor Harness	27-2
5887 5635	Middle Sensor Harness	37-2
5887 5652	Upper Solenoid Control Board	11-20
5887 5652	Upper Solenoid Control Board	15-*
5887 5662	Lower Solenoid Control Board	11-21
5887 5662	Lower Solenoid Control Board	17-*
5887 5701	Main Harness	13-37
5887 5701	Main Harness	27-3
5887 5701	Main Harness	29-1
5887 5710	Power Supply Harness	13-36
5887 5710	Power Supply Harness	27-4
5887 5710	Power Supply Harness	31-1
5887 5720	Transport Harness	27-5
5887 5720	Transport Harness	35-1
5887 5720	Transport Harness	9-58
5887 5730	Door Switch Harness	27-6
5887 5730	Door Switch Harness	33-1
5887 5732	Upper Door Switch - 115V	9-32
5887 5733	Upper Door Switch - 220/240V	9-32
5887 5740	Clutch Harness	13-38
5887 5740	Clutch Harness	27-7

Parts No.	Description	Page and Index No.
5887 5740	Clutch Harness	37-3
5887 5780	Grounding Wire	13-34
5887 5781	Grounding Wire - Sorter Main P.C.B.	13-29
5887 5782	Grounding Wire - Front Cover	5-34
5887 9001	Transport Belt - 6pcs/set	7-7
5918 5711	Fiber Output Connector	23-1
5918 5712	Fiber Input Connector	23-2
5918 5722	Photo Sensor	9-42
5937 1153	Cover - Signal Harness Bracket	13-30
5937 1154	Transformer Cover	13-13
5937 1155	Bracket - Power Supply Cord	13-6
5937 1161	Front Connector Bracket	5-15
5937 1164	Rear Connector Bracket	5-6
5937 1254	Magnet Bracket	5-13
5937 1265	Rear Safety Cover	11-55
5937 1266	Lower Safety Cover	11-32
5937 1270	Front Safety Cover	5-16
5937 2110	Driving Side Plate	13-18
5937 2114	Bushing - Driving Side Plate	13-32
5937 2130	Tightener - Magnetic Clutch	13-16
5937 2140	Driving Shaft	13-26
5937 2160	Magnetic Clutch	13-23
5937 2241	Support Plate - Timing Pulley	13-4
5937 2245	Spring Anchor	13-3
5937 2330	Distribution Unit Link	11-27
5937 2410	Lower Insulating Sheet	11-68
5937 3101	Front Side Plate - Transport	9-59
5937 3111	Rear Side Plate - Transport	9-57
5937 3120	Lower Roller Ass'y - Belt Drive	7-12
5937 3125	Upper Belt Guide	9-34
5937 3131	Lower Roller - Belt Drive	7-30
5937 3136	Belt Tension Roller	7-15
5937 3138	Belt Guide Rller	7-16
5937 3139	Lower Belt Guide	9-33
5937 3154	Spring - Transport Drive	7-23

Parts No.	Description	Page and Index No.
5937 3181	Bracket - Copy Timing Sensor	9-44
5937 3182	Safety Cover - Copy Timing Sensor	9-39
5937 3184	Spacer - Sensor	9-43
5937 3266	Bracket Guide Plate	9-16
5937 3267	Exit Guide Plate	9-17
5937 3325	Manual Feed Solenoid	9-6
5937 4101	Front Guide - Distribution Drive	11-46
5937 4110	Rear Guide - Distribution Drive	11-31
5937 4121	Bracket - Distribution Sensor	11-13
5937 4122	Lower Sensor Bracket	11-50
5937 4158	Spring Washer - BD10	11-65
5937 4159	Turn Lever	11-9
5937 4161	Cushion - Turn Lever	11-24
5937 4164	Turn Solenoid	11-22
5937 4168	Small Guide Bracket - Driven Unit	11-60
5937 4173	Driven Guide Bracket	11-8
5937 4200	Distribution Driven Unit	11-2
5937 4210	Driven Link Bracket	11-1
5937 4360	Driven Lever Bracket	11-58
5937 4390	Driven Unit Guide	9-36
5937 4401	Stud - Upper Guide Roller	11-54
5937 4470	Cover - Main Control (115V)	13-43
5937 4530	Inside Vibration Damper	5-29
5937 4531	Bottom Vibration Damper	5-30
5937 4532	Upper Vibration Damper	5-31
5937 4533	Lower Vibration Damper	5-32
5937 5420	Fuse Holder - 115V	13-7
5937 5460	Transformer - 100V	13-14
5937 5604	IC - SI-3242P	23-4
5937 5612	Sorter Main Board	13-39
5937 5612	Sorter Main Board	23-*
5937 5613	IC - HN4827128G-25	23-3
5937 5627	Rubber Tube (220V)	11-67
5937 5632	Receiver Sensor Board	11-14
5937 5632	Receiver Sensor Board	19-*

Parts No.	Description	Page and Index No.
5937 5705	Registration Sensor Harness	9-35
5937 5710	Power Supply Cord - 220/240V	13-41
5937 5711	Power Supply Cord - 115V	13-41
5937 5772	Optical Fiber Cable	13-5
5937 5782	Granding Wire	13-44
5946 3177	Transport Stay Bracket	9-41

Parts No.	Description	Page and Index No.
0313 0040W	Philips Pan Head Screw - M3x4	13-110
0313 0040W	Philips Pan Head Screw - M3x4	9-116
0313 0060W	Philips Pan Head Screw - M3x6	5-115
0313 0060W	Philips Pan Head Screw - M3x6	9-108
0313 0080W	Philips Pan Head Screw - M3x8	9-102
0313 0100W	Philips Pan Head Screw - M3x10	11-115
0313 0120W	Philips Pan Head Screw - M3x12	13-111
0313 0250W	Philips Pan Head Screw - M3x25 (115V)	5-118
0313 0250W	Philips Pan Head Screw - M3x25 (115V)	9-118
0313 0350W	Philips Pan Head Screw - M3x35 (220V)	5-118
0313 0350W	Philips Pan Head Screw - M3x35 (220V)	9-118
0314 0060W	Philips Pan Head Screw - M4x6	11-101
0314 0060W	Philips Pan Head Screw - M4x6	13-101
0314 0060W	Philips Pan Head Screw - M4x6	5-101
0314 0060W	Philips Pan Head Screw - M4x6	7-101
0314 0060W	Philips Pan Head Screw - M4x6	9-101
0314 0080W	Philips Pan Head Screw - M4x8	11-102
0314 0080W	Philips Pan Head Screw - M4x8	13-102
0314 0080W	Philips Pan Head Screw - M4x8	5-102
0314 0080W	Philips Pan Head Screw - M4x8	7-102
0314 0100W	Philips Pan Head Screw - M4x10	13-118
0314 0100W	Philips Pan Head Screw - M4x10	9-110
0314 0160W	Philips Pan Head Screw - M4x16	13-112
0315 0080W	Philips Pan Head Screw - M5x8	5-112
0315 0120W	Philips Pan Head Screw - M5x12	5-114
0315 0400W	Philips Pan Head Screw - M4x40	13-116
0344 0080D	Philips Truss Head Screw - M4x8	5-109
0573 0040E	Hexagon Headless Set Screw - M3x4	11-109
0574 0040E	Hexagon Headless Set Screw - M4x4	11-110
0574 0040E	Hexagon Headless Set Screw - M4x4	13-108
0575 0050E	Hexagon Headless Set Screw - M5x5	7-110
0575 0060E	Hexagon Headless Set Screw - M5x6	11-107
0575 0060E	Hexagon Headless Set Screw - M5x6	13-107
0575 0060E	Hexagon Headless Set Screw - M5x6	5-107
0575 0060E	Hexagon Headless Set Screw - M5x6	7-107

Parts No.	Description	Page and Index No.
0575 0060E	Hexagon Headless Set Screw - M5x6	9-107
0623 0180E	Spring Pin - 3x18mm	7-113
0701 0050E	Flat Washer - M5	9-117
0704 0040M	Toothed Washer - M4	5-120
0710 0030W	Hexagon Nut - M3	11-114
0720 0030E	Retaining Ring - M3	11-111
0720 0030E	Retaining Ring - M3	9-111
0720 0040E	Retaining Ring - M4	11-103
0720 0040E	Retaining Ring - M4	13-103
0720 0040E	Retaining Ring - M4	5-103
0720 0040E	Retaining Ring - M4	7-103
0720 0040E	Retaining Ring - M4	9-103
0720 0050E	Retaining Ring - M5	11-104
0720 0050E	Retaining Ring - M5	13-104
0720 0050E	Retaining Ring - M5	5-104
0720 0050E	Retaining Ring - M5	7-104
0720 0050E	Retaining Ring - M5	9-104
0720 0060E	Retaining Ring - M6	11-105
0720 0060E	Retaining Ring - M6	13-105
0720 0060E	Retaining Ring - M6	5-105
0720 0060E	Retaining Ring - M6	7-105
0720 0060E	Retaining Ring - M6	9-105
0720 0080E	Retaining Ring - M8	7-111
0801 1185	Phillips Truss Head Screw - M4x8	13-120
0801 1185	Phillips Truss Head Screw - M4x8	5-108
0801 1185	Phillips Truss Head Screw - M4x8	5-119
0802 5086	Tapping Screw - M4x10	9-115
0805 3145	Ball Bearing - 6x12x4mm	11-108
0805 3145	Ball Bearing - 6x12x4mm	13-125
0805 3145	Ball Bearing - 6x12x4mm	7-108
0805 3162	Ball Bearing - 10x19x7mm	7-114
0805 3260	Ball Bearing - 15x17x5mm	13-109
0805 3291	Ball Bearing - 8x16x5mm	7-109
0805 5003	Caster	5-113
0807 3093	Washer - 4.1x5.3x7mm	13-113

Parts No.	Description	Page and Index No.
0807 4064	Spacer - 6.2x9.5x0.2mm	11-117
0951 3006W	Phillips Screw With Flat Washer - M3x6	9-109
0951 4008W	Phillips Screw With Flat Washer - M4x8	13-124
0951 4016W	Phillips Flange Screw - M4x16	11-116
0951 4016W	Phillips Screw With Flat Washer - M4x16	5-111
0965 4010W	Tapping Screw With Flat Washer - M4x10	13-114
0965 4010W	Tapping Screw With Flat Washer - M4x10	5-110
0965 4010W	Tapping Screw With Flat Washer - M4x10	5-116
0965 4010W	Tapping Screw With Flat Washer - M4x10	9-112
1005 0335	Earth Mark	13-123
1100 1042	Socket - Mate-N-Lock	31-102
1100 1147	Socket - Mate-N-Lock	29-101
1100 1147	Socket - Mate-N-Lock	31-103
1100 1147	Socket - Mate-N-Lock	33-101
1100 1147	Socket - Mate-N-Lock	35-101
1100 1147	Socket - Mate-N-Lock	37-101
1100 1155	Contact	31-104
1100 1155	Contact	35-102
1100 1159	Socket - Mate-N-Lock	29-102
1100 1159	Socket - Mate-N-Lock	31-105
1100 1159	Socket - Mate-N-Lock	33-102
1100 1159	Socket - Mate-N-Lock	35-103
1100 1159	Socket - Mate-N-Lock	37-105
1100 1169	Fastening Receptacle	33-103
1100 1172	Fastening Receptacle	31-106
1100 1182	Socket - Mate-N-Lock	29-103
1100 1239	Pin - Mate-N-Lock	31-101
1100 1239	Pin - Mate-N-Lock	33-104
1100 1241	Socket - Mate-N-Lock	31-107
1100 1241	Socket - Mate-N-Lock	33-105
1100 1274	Fastening Receptacle	37-102
1101 0359	Terminal - 3P	13-126
1101 0406	Terminal - 4P	13-127
1102 0782	Pin Housing - Mate-N-Lock	31-108
1102 0911	Connector - 8P	23-101

Parts No.	Description	Page and Index No.
1102 0983	Connector - 2P	31-109
1102 0995	Connector - 2P	23-102
1102 1039	Connector - 4P	23-103
1102 1055	Connector - 2P	15-101
1102 1055	Connector - 2P	17-101
1102 1056	Connector - 4P	15-102
1102 1056	Connector - 4P	17-102
1102 1213	Connector - 4P	29-104
1102 1213	Connector - 4P	37-103
1102 1244	Connector - 15P	29-105
1102 1286	Connector	31-110
1102 1286	Connector	35-104
1102 1291	Connector - 8P	31-111
1102 1293	Connector - 10P	29-106
1102 1293	Connector - 10P	35-105
1102 1295	Connector - 12P	29-107
1102 1308	Connector - 6P	29-108
1102 1308	Connector - 6P	37-106
1102 1309	Connector - 8P	31-112
1102 1309	Connector - 8P	33-106
1102 1396	Connector - 2P	31-113
1102 1396	Connector - 2P	35-106
1102 1396	Connector - 2P	37-107
1102 1404	Receptacle Housing	31-114
1102 1408	Connector - 1P	33-107
1102 1507	Connector - 2P	31-115
1102 1507	Connector - 2P	33-108
1102 1515	Connector - 2P	31-116
1102 1517	Connector - 4P	33-109
1102 1518	Connector - 6P	31-117
1102 1791	Connector - 3P	21-101
1102 1792	Connector - 4P	19-101
1102 1793	Connector - 3P	37-109
1102 1794	Connector - 4P	37-104
1102 2566	Connector - 2P	23-104

Parts No.	Description	Page and Index No.
1103 0505	Connector - 3P	17-103
1103 0510	Connector - 10P	15-103
1103 0512	Connector - 12P	15-104
1103 0512	Connector - 12P	17-104
1103 0515	Connector - 15P	25-101
1103 0600	Connector - 3P	33-110
1103 0600	Connector - 3P	35-107
1103 0600	Connector - 3P	37-108
1103 0657	Connector - 50P	29-109
1103 0755	Connector - 50P	23-105
1104 0291	Fuse Holder Case	13-131
1104 0307	Fuse Clip	23-106
1105 0005	Nylon Clip - 3N	13-117
1105 0008	Nylon Clip - 2N	11-113
1105 0009	Nylon Clip - 5N	13-119
1105 0011	Nylon Clip - 8N	13-121
1105 0016	Nylon Clip - 4N	13-115
1105 0016	Nylon Clip - 4N	13-122
1105 0016	Nylon Clip - 4N	9-113
1106 0101	Cord Stopper	13-129
1106 0167	Bushing - 11mm	9-114
1106 0241	Bushing - 6.7mm	11-112
1106 0368	Nylon Stud	13-128
1107 0265	Fuse - 3A (220/240V)	13-130
1107 0411	Fuse - 2A	23-107
1107 0413	Fuse - 3A (115V)	13-130
1107 0413	Fuse - 3A	23-108
1204 0758	DIP Switch	23-109
1204 0790	DIP Switch	25-102
1204 0795	Microswitch - 220/240V	5-117
1204 1151	Microswitch - 115V	5-117
1204 1202	Microswitch - 220/240V	9-119
1204 1211	Microswitch - 115V	9-119
1204 1385	Push Switch	23-110
1208 1024	Solid State Relay - 220/240V	23-111

Parts No.	Description	Page and Index No.
1400 0045	Transistor - 2SC372	19-102
1400 0113	Transistor - 2SA495GTM Y	21-102
1400 0236	Transistor - 2SK30A-GR	19-103
1400 0284	Transistor - 2SD789D	21-103
1400 0323	Transistor - PN108	19-104
1401 0192	IC - μ PA2003C	15-105
1401 0192	IC - μ PA2003C	17-105
1401 0192	IC - μ PA2003C	23-112
1401 0234	Transistor - 2SD686	23-113
1401 0611	Diode - 1S1588	25-103
1401 0832	Diode - DSA1A1	23-114
1402 0247	Diode - W06B	31-118
1402 0247	Diode - W06B	35-108
1402 0291	Rectifier - S2VB10	23-115
1402 0481	Zener Diode - HZ18-2	19-105
1403 0247	LED - LN51L	21-104
1403 0308	LED - TLR-102A	23-116
1403 0308	LED - TLR-102A	25-104
1407 0711	IC - 74LS151N	23-117
1407 0887	IC - SN74LS244N	23-118
1407 1026	IC - SN74LS373N	23-119
1407 1334	IC - UPD7810G	23-120
1407 1607	IC - TD62603P	23-121
1407 1698	IC - TD62801P	23-122
1408 0099	IC - HA17901P	25-105
1408 0124	IC - LM555CN	21-105
1408 0383	IC - S1-3052V	23-123
1408 0408	IC - PST518A	23-124
1503 0070	Ceramic Oscillator - 10MHz	23-125
1600 0544	Resistor - 1KOHM 1T \pm 1%	23-126
1600 0549	Resistor - 82OHM 2T \pm 10%	21-106
1601 7284	Resistor Array - 4.7KOHM 1/8W \pm 5%	23-127
1601 7348	Resistor Array - 470OHM 1/8W \pm 5%	23-128
1601 7349	Resistor Array - 1.5KOHM 1/8T \pm 5%	23-129
1601 7352	Resistor Array - 4.7KOHM	23-130

Parts No.	Description	Page and Index No.
1601 7370	Resistor Array - 1KOHM	23-131
1601 7371	Resistor Array - 1.5KOHM	23-132
1601 7374	Resistor Array - 4.7KOHM	23-133
1601 8139	Variable Resistor - 50KOHM 0.5W	25-106
1602 0911	RC Array - RC082	23-134
1604 0938	Capacitor - 4700 μ F 35V	23-135
1604 0987	Capacitor - 10MF 16V	23-136
1604 1130	Capacitor - 2200 μ F 50V	23-137
1604 1254	Capacitor - 47 μ F 50V	23-138
1604 1320	Capacitor - 10 μ F 50V	19-106
1604 1320	Capacitor - 10 μ F 50V	25-107
1604 1321	Capacitor - 0.47 μ F 50V	19-107
1604 1321	Capacitor - 0.47 μ F 50V	25-108
1606 0531	Capacitor - 0.01 μ F 50V	19-108
1606 0531	Capacitor - 0.01 μ F 50V	21-107
1606 0533	Capacitor - 0.01 μ F 50V	21-108
1606 0533	Capacitor - 0.01 μ F 50V	23-139
1606 0533	Capacitor - 0.01 μ F 50V	25-109
1606 0658	Capacitor - 0.1 μ F 50V	23-140
1606 1430	Capacitor - 27PF 50V	23-141
1611 4102	Resistor - 1KOHM 1/4T \pm 5%	19-109
1611 4102	Resistor - 1KOHM 1/4T \pm 5%	23-142
1611 4102	Resistor - 1KOHM 1/4T \pm 5%	25-110
1611 4103	Resistor - 10KOHM 1/4T \pm 5%	19-110
1611 4103	Resistor - 10KOHM 1/4T \pm 5%	23-143
1611 4105	Resistor - 1KOHM 1/4T \pm 5%	19-111
1611 4106	Resistor - 10MOHM 1/4T \pm 5%	23-144
1611 4122	Resistor - 1.2KOHM 1/4T \pm 5%	25-111
1611 4152	Resistor - 1.5KOHM 1/4T \pm 5%	21-114
1611 4152	Resistor - 1.5KOHM 1/4T \pm 5%	23-145
1611 4154	Resistor - 150KOHM 1/4T \pm 5%	21-109
1611 4182	Resistor - 1.8KOHM 1/4T	21-110
1611 4223	Resistor - 22KOHM 1/4T \pm 5%	21-111
1611 4225	Resistor - 2.2KOHM 1/4T \pm 5%	19-112
1611 4272	Resistor - 2.7KOHM 1/4T \pm 5%	25-112

Parts No.	Description	Page and Index No.
1611 4471	Resistor - 470OHM 1/4T \pm 5%	19-113
1611 4472	Resistor - 4.7KOHM 1/4T \pm 5%	19-114
1611 4472	Resistor - 4.7KOHM 1/4T \pm 5%	23-146
1611 4472	Resistor - 4.7KOHM 1/4T \pm 5%	25-113
1611 4473	Resistor - 47KOHM 1/4T \pm 5%	19-115
1611 4473	Resistor - 47KOHM 1/4T \pm 5%	21-112
1611 4473	Resistor - 47KOHM 1/4T \pm 5%	23-147
1611 4473	Resistor - 47KOHM 1/4T \pm 5%	25-114
1611 4563	Resistor - 56KOHM 1/4T \pm 5%	21-113

Parts No.	Description	Page and Index No.
-----------	-------------	--------------------